

**Re-burn Checklist.**

To have your programming updated for new modifications please fill out the form below and return the chip or adapter along with a Check/Money order in the amount of \$50 + Shipping\*. Please note: Credit/debit card payments can be made easily on our website.

**FOR FASTER SERVICE PLEASE PAY VIA OUR WEBSITE**

**[www.pcmforless.com](http://www.pcmforless.com)**

PCMforless of NC, Inc  
106 Performance Rd  
Mooresville, NC 28115

Name: \_\_\_\_\_

Address: \_\_\_\_\_

City: \_\_\_\_\_ State: \_\_\_\_\_

I made the following changes to my car:

---

---

---

---

Attach separate sheet if necessary.

Thank You,  
PCMforless

\* Shipping Charges  
\$5 (4-10 Day) USPS First class  
\$7 (2-3 Day) Priority  
\$20 (1-2 Day) Express



Custom programming owner's manual

Sold to: \_\_\_\_\_

Installation of PCMforless Memory Adapter:

Please take note of the illustration below. The PCMforless memory adapter plugs into your STOCK PROM, and then the WHOLE ASSEMBLY plugs back into the PCM. All Pcmforless adapters must be installed with a stock style prom of the same application. Example: 91 Camaro 5.7 V8 must have a stock prom for 91 F-body with V8. Different Displacement OK. A V6 prom would not work in this application. Note: Some early computers require removing the case cover. It can be done in less than 5 minutes with a ¼" driver.

If you have any problems with the chip or programming please call 704-307-4227. OR email sales@pcmforless.com.

Contact us before returning any chip. Any chip returned for any reason will be returned 4-10 day USPS ground unless other shipping arrangements are made.

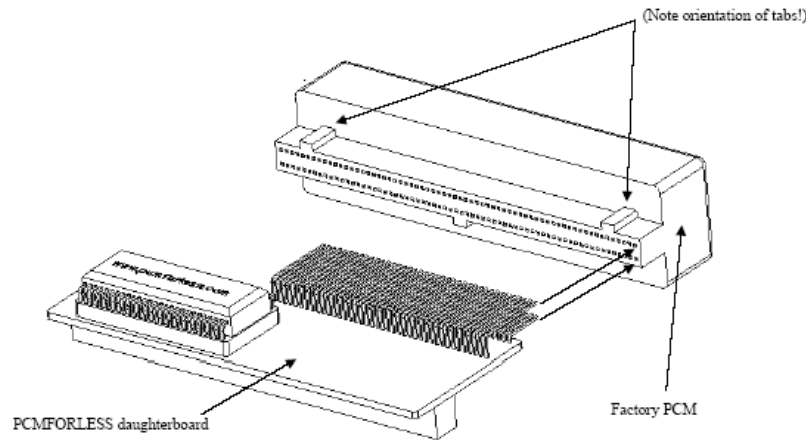

Typical Locations of ECM/PCM

Year	Model	Location/Color
93	Z28, Formula, Trans am	Under cowl pass side. Black
85-92	Z28, Formula, Trans am, IROC	Above pass foot area. Silver
85-89	Corvette	Above pass foot area. Silver
90-93	Corvette	Under hood drivers side. Black.
87-95	Full Size Pickup	Above pass foot area. Silver
87-94	S-10 S-15 Blazer Jimmy	Above pass foot area. Silver.

Setup	Procedure
Ignition Timing	If applicable set to factory specifications with ESC disconnected (typically tan/white wire with disconnect)
Fuel pressure	Start with stock, Welcome to adjust from there. Should only need very minor tweaks
IAC, Idle Air Control	Look for 30-50 counts at idle. Check <a href="http://www.pcmforless.com">www.pcmforless.com</a> FAQ for more info.
TPS	Factory specifications, Check service manual.

For more help concerning idle setup visit <http://www.pcmforless.com/images/datalog/datalog.htm#Idle%20Setup>  
 Datalog help <http://www.pcmforless.com/images/datalog/datalog.htm>